

SMD Power Inductor Size 6020

- Shielded construction.
- Capable of corresponding high frequency.
- Low loss realized with low DCR.
- High performance (Isat) realized by Carbonyl Powder.
- Ultra low buzz noise, due to composite construction.
- 100% Lead(Pb)-Free and RoHS compliant.
- AEC-Q200 qualified.
- Operating temperature: -55 to +125 °C(including self-temperature rise)
- Quantity: 1500pcs

- Headlamps, tail lamps and interior lighting.
- HVAC.
- Doors, window/line and seat control.
- Audio subsystem.
- Digital instrument cluster.
- In-Vehicle Infotainment and navigation.

Dimensions: [mm]

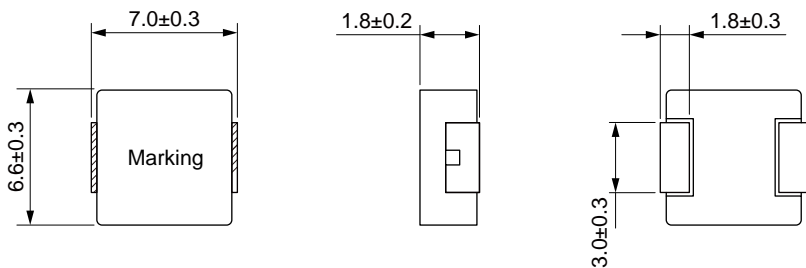

Land Pattern: [mm]

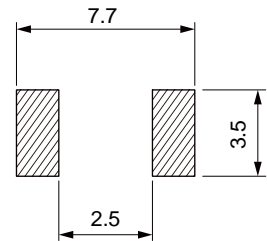

Electrical Properties:

Temperature Rise Current (A)	Current (A)		
21.0		20	24
18.0		23	27
15.0	κ	35	40
14.0	κ	45	50
11.7	κ	7.1	8.3
11.0	κ	7.9	9.3
10.5	κ	8.3	10.0
8.0	κ	16.5	18.0
7.0	κ	23.0	27.0
6.0	κ	32.0	37.0

Part No	Inductance @ 100KHz/1V	Tolerance				
	10.0		2.8	4.0		154
MDCA6020-150M	15.0		2.1	3.3		
	22.0		1.5	2.5		

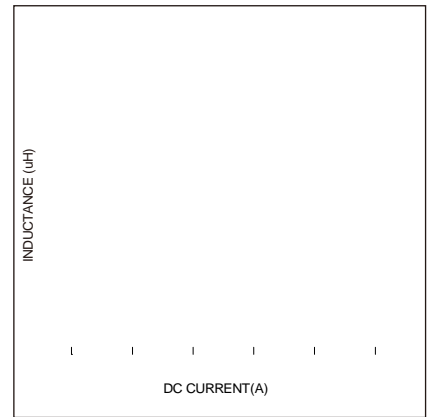

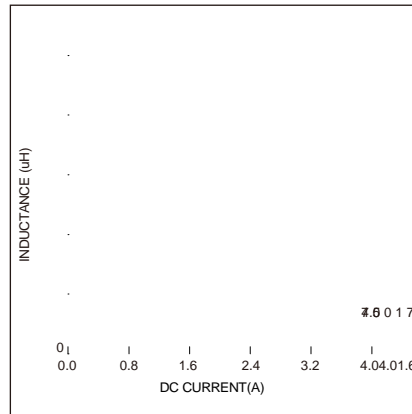
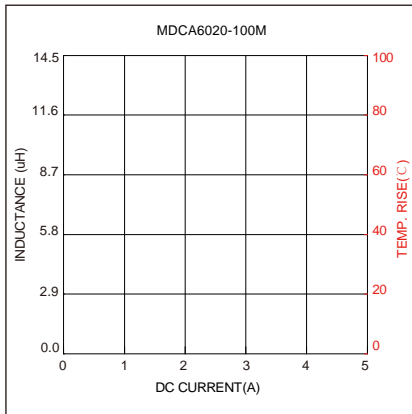
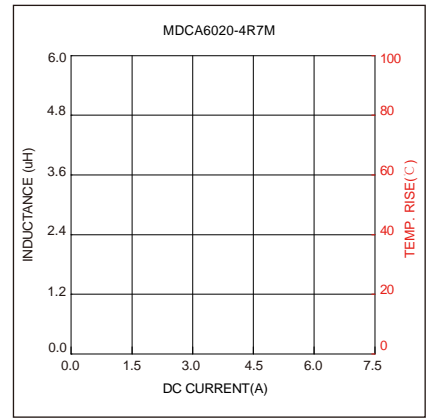
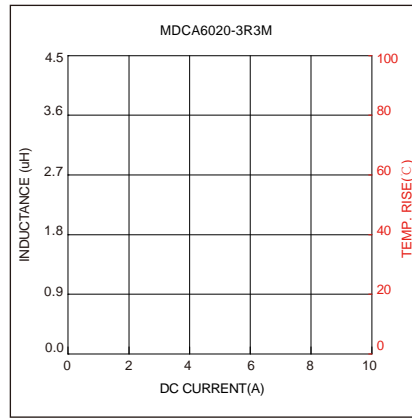

4.6 0 1 78 923.61 6.44365 cm0 0 m0 0 ISQq 1Qq 1 0 0 1 192.8622 316.4365 cm0 0 m0 2.666 ISQq 1 0 0

Soldering Reflow:

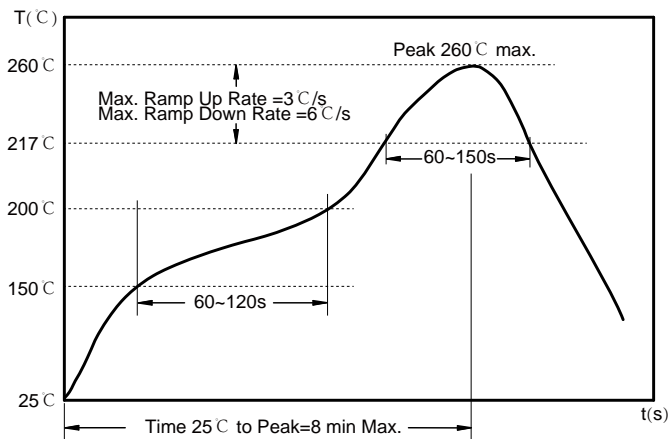

Preheat condition: 150 ~200°C / 60~120 sec.

Allowed time above 217°C : 60~150 sec.

Max temperature: 260°C.

Allowed Reflow time: 2x max.

Packaging Information:

Tape Dimension :

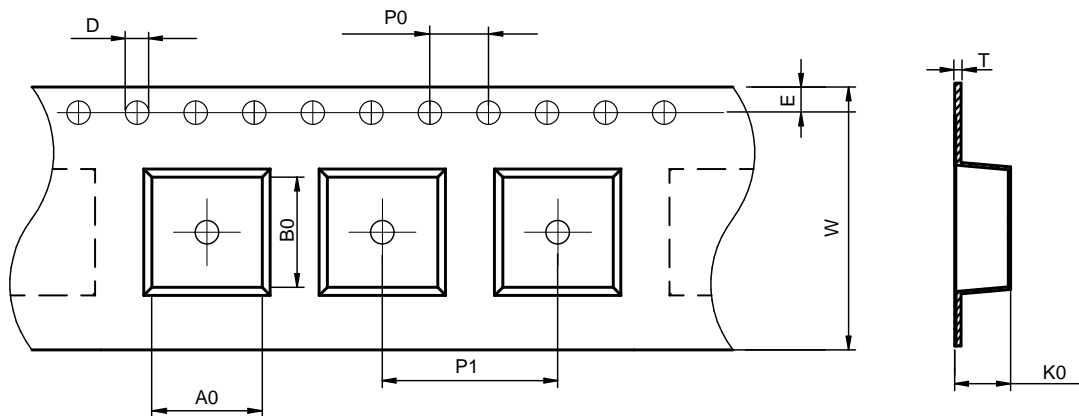

Series	A0 (mm)	B0 (mm)	D (mm)	P0 (mm)	P1 (mm)	W (mm)	K0 (mm)	E (mm)	T (mm)
MDCA6020	7.0± 0.1	7.7± 0.1	1.5± 0.1	4.0± 0.1	12.0± 0.1	16.0± 0.3	2.3± 0.1	1.75± 0.1	0.35± 0.05

Peel force of top cover tape:

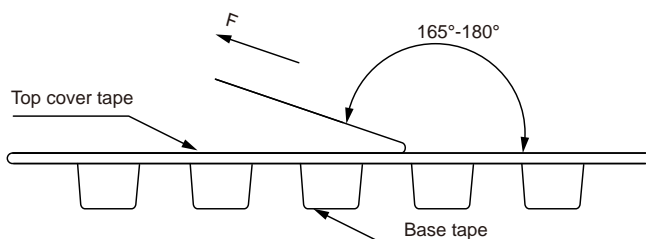

The peel force of top cover tape shall be between 0.1 to 1.3 N

Product Marking:

Marking	Printing Inductance+period)
---------	-----------------------------

Reel Dimension: [mm]

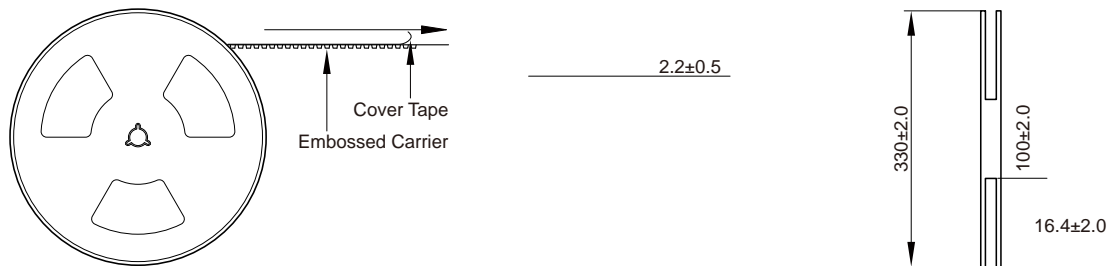

Packaging Quantity:

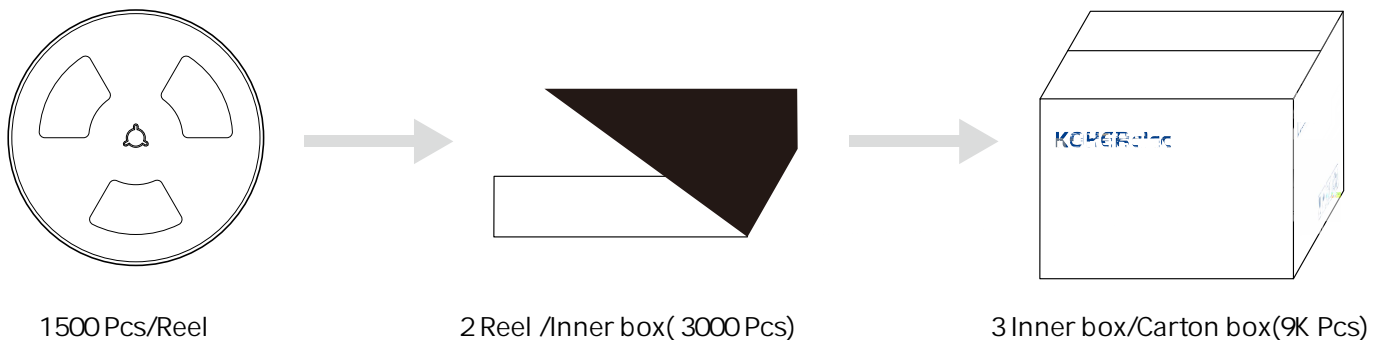

Cautions and Warnings:

Storage Conditions:

- The storage period is within 12 months after the completion of production. Be sure to follow the storage conditions (temperature: -5 to 35°C , humidity: 75% RH Max). If the storage period elapses, the soldering of the terminal electrodes may deteriorate. The warranty period is one year.
- Product should not be exposed to environment with high temperature, high humidity, dust, corrosive gas and etc.
- Products should be handled with care to avoid damage or contamination from perspiration and skin oils.
- Please always handle products carefully to prevent any damage caused by dropping down or inappropriate removing.

Operation Instructions:

- Self heating (temperature increase) occurs when the power is turned ON, so the tolerance should be sufficient for the set thermal design.
- Before soldering, be sure to preheat components. The preheating temperature should be set so that the temperature difference between the solder temperature and chip temperature does not exceed 150°C .
- Soldering corrections after mounting should be within the range of the conditions determined in the specifications. If overheated, a short circuit, performance deterioration, or lifespan shortening may occur.
- Generally, Koher might not be familiar with either customer's specific application or actual requests as customer does. As a result customer shall be responsible for checking and confirming whether Koher product with the performance described in the product specification is suitable for using in customer's particular application or not. [Label](#)